

# HSF

**NOTES:**

- Rated Current: 5.0AMP.(20°C, 2\*2P-2\*15P)  
3.0AMP.(20°C, 2\*16P-2\*40P) A2
- Contact Resistance: 20mΩ Max.
- Withstand Voltage: 1000V AC/DC
- Insulation Resistance: 1000MΩ Min.
- Operation Temperature: -40°C to +125°C (Gold Plating)  
-40°C to +105°C (Tin Plating) A2
- Contact Material: Copper Alloy
- Contact Plating: Au or Sn Over 30u" Min Ni A1
- Insulator Material: PA9T+G.F UL94V-0 BK A2

## Ordering Information

1115- 1 2 XX XX R XXX C 0 XX A1

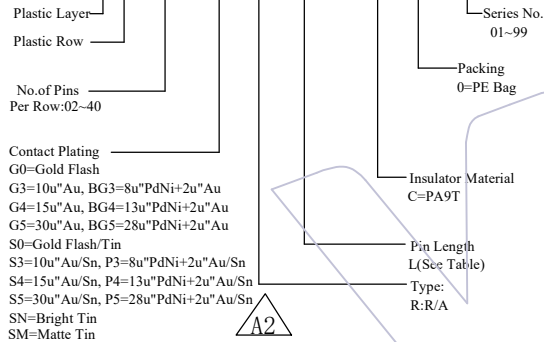

Item	Pin Length (Short/Long)	A	D	E	B	Mating
Standard	10.3/15.3	3.00	1.2	3.02	3.5	2135/2150T/2157
	10.8/15.8				4.0	2145/2150
	11.8/16.8				5.0	2168T/2171T
	12.5/17.5				5.84	2171/2185X
Standard	9.3/14.3	2.0 (THR)	1.2	3.02	3.5	2135/2150T/2157
	9.8/14.8				4.0	2145/2150
	10.8/15.8				5.0	2168T/2171T
	11.5/16.5				5.84	2171/2185X
Alternate						

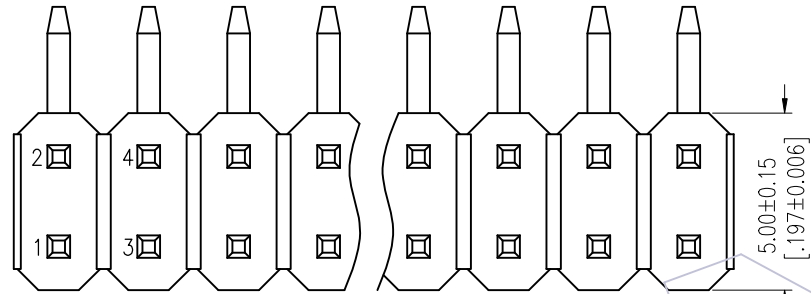

Recommended P.C.B Layout (Top Side)  
(PCB BOARD TOLERANCE ±0.05)  
(PCB Thickness: T=1.60mm)

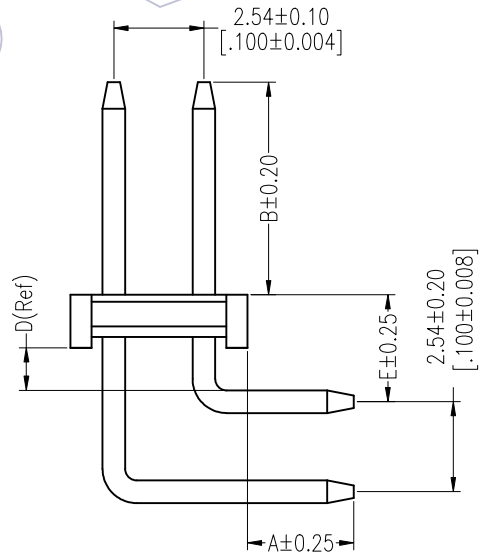
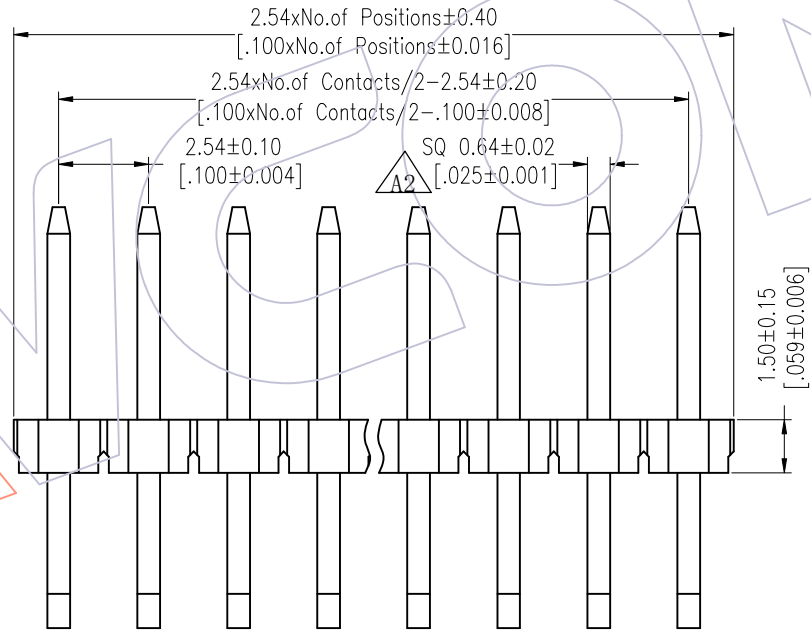
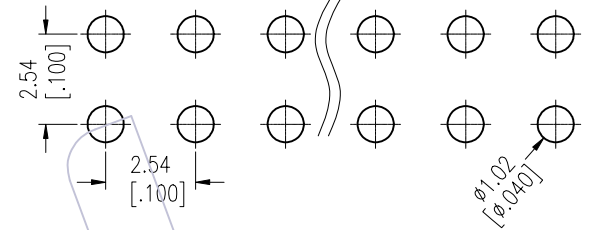

REV	DATE	MODIFICATION DESCRIPTION	CHANGE	OPERATION	DRAW	DATE	SCALE	Fit	PART NO.
A2	2025/03/19	Standardization Drawing	CP	x.X ±0.40	CP	2025/03/19	UNIT	mm	1115-12XXXXRXXXCOXX
A1	2018/01/22	Modify P/N	Ruipeng	x.xx ±0.25	CHECK	DATE	SIZE	A4	TITLE:
AO	2012/05/02	NEW	William Chen	x.xxx ±0.15	TANG	2025/03/19	SHEET	1/2	PH2.54 DUAL ROW 90° H=1.5 CONCAVE BENDING
				Angle ± 3'	APPROVE	DATE	PROJ.		Customer NO.
				DIM TOL	Steven Zhao	2025/03/19			

# WCON

Http: www.wcon.com

WCON-Dongguan  
Tel: +86 769 85358920  
Fax: +86 769 85358915  
E-mail: sales@wcon.com

WCON-Kunshan  
Tel: +86 512 57468408  
Fax: +86 512 57468468  
E-mail: salesks@wcon.com

**HSF**

**Packing:**

**Packaging Quantity Refers To The Following Table**

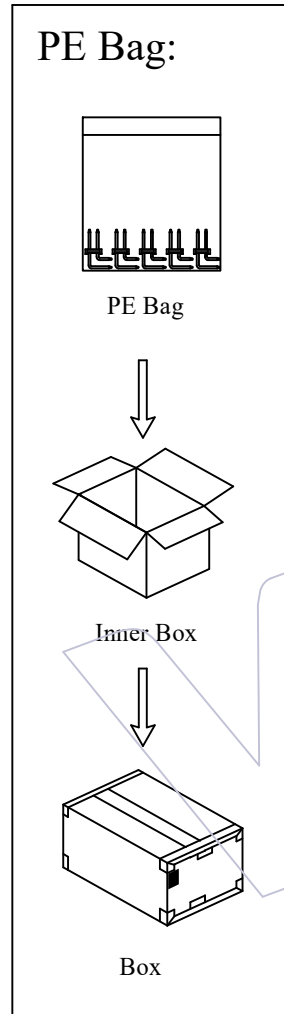

PINS /Row	Q' ty/Bag L≤10.0	PINS /Row	Q' ty/Bag L≤10.0
1	1,000	21	100
2	1,000	22	100
3	1,000	23	100
4	1,000	24	100
5	500	25	100
6	500	26	100
7	500	27	100
8	500	28	100
9	500	29	100
10	500	30	100
11	300	31	100
12	300	32	100
13	300	33	100
14	300	34	100
15	200	35	100
16	200	36	100
17	200	37	100
18	200	38	100
19	200	39	100
20	100	40	100

PINS /Row	Q' ty/Bag 10.0<L≤16.0	PINS /Row	Q' ty/Bag 10.0<L≤16.0
1	1,000	21	100
2	1,000	22	100
3	1,000	23	100
4	500	24	100
5	500	25	100
6	500	26	100
7	300	27	100
8	300	28	100
9	200	29	100
10	200	30	50
11	200	31	50
12	200	32	50
13	200	33	50
14	200	34	50
15	200	35	50
16	200	36	50
17	200	37	50
18	200	38	50
19	200	39	50
20	100	40	50

REV	DATE	MODIFICATION DESCRIPTION	CHANGE	OPERATION	DRAW	DATE	SCALE	Fit	PART NO.
A2	2025/03/19	Standardization Drawing	CP	x.X ±0.40	CP	2025/03/19	UNIT	mm	1115-12XXXXRXXXCOXX
A1	2018/01/22	Modify P/N	Ruipeng	x.XX ±0.25	CHECK	DATE	SIZE	A4	TITLE:
AO	2012/05/02	NEW	William Chen	x.XXX ±0.15	TANG	2025/03/19	SHEET	2/2	PH2.54 DUAL ROW 90° H=1.5 CONCAVE BENDING
				Angle ± 3'	APPROVE	DATE	PROJ.		Customer NO.
				DIM TOL	Steven Zhao	2025/03/19			



Http: [www.wcon.com](http://www.wcon.com)

WCON-Dongguan Tel: +86 769 85358920 Fax: +86 769 85358915 E-mail: <a href="mailto:sales@wcon.com">sales@wcon.com</a>	WCON-Kunshan Tel: +86 512 57468408 Fax: +86 512 57468468 E-mail: <a href="mailto:salesks@wcon.com">salesks@wcon.com</a>
---	--