

# HSF

**NOTES:**

- Rated Current: 5.0AMP. (20°C, 2\*2P-2\*15P)
- 3.0AMP. (20°C, 2\*16P-2\*40P)  $\triangle A3$
- Contact Resistance: 20m $\Omega$  Max.
- Withstand Voltage: 1000V AC/DC
- Insulation Resistance: 1000M $\Omega$  Min.
- Operation Temperature: -40°C to +125°C (Gold Plating)
- 40°C to +105°C (Tin Plating)  $\triangle A3$
- Contact Material: Copper Alloy
- Contact Plating: Au or Sn Over 30u" Min Ni  $\triangle A3$
- Insulator Material: PA9T+G.F UL94V-0 BK  $\triangle A3$

## Ordering Information

1115- 1 2 XX XX R XXX C 0 XX  $\triangle A2$

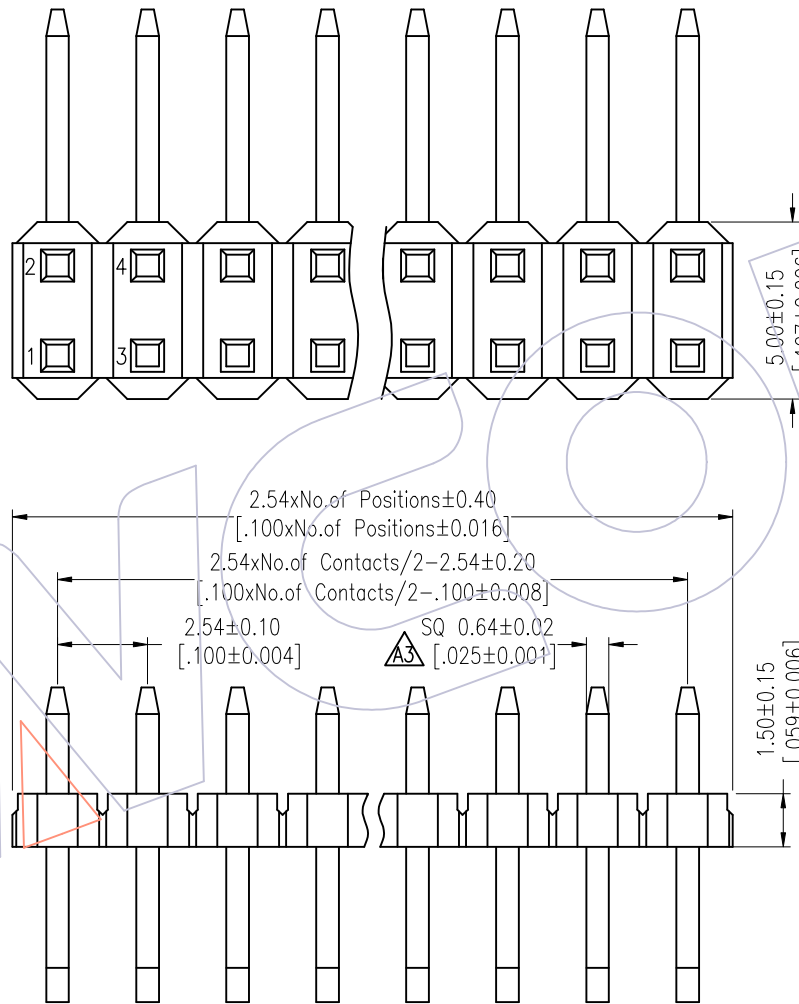
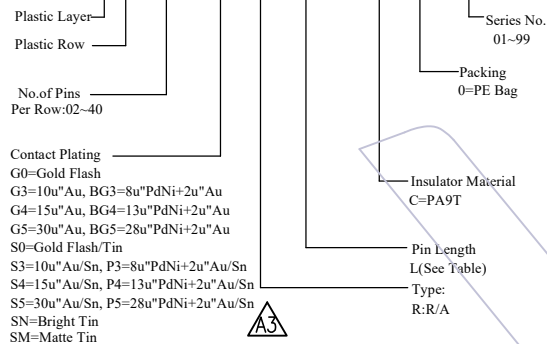

Recommended P.C.B Layout (Top Side)  
(PCB BOARD TOLERANCE  $\pm 0.05$ )  
(PCB Thickness: T=1.60mm)

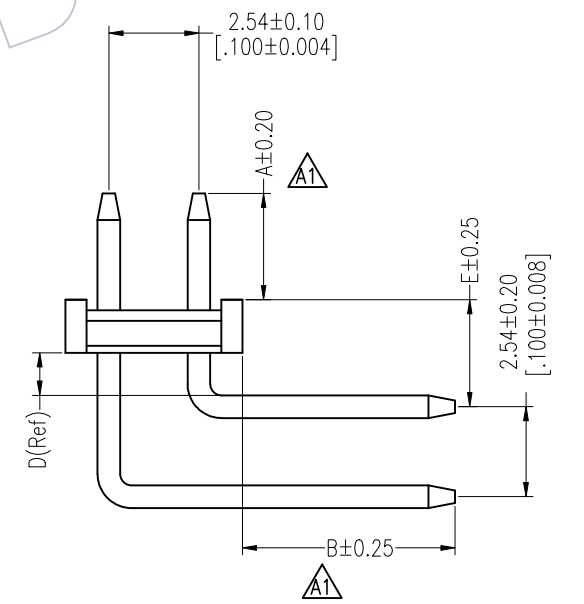
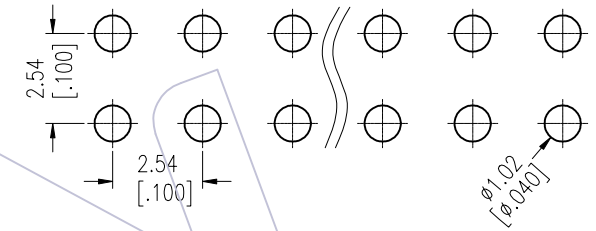

Item	Pin Length (Short/Long)	A	D	E	B	Mating
Standard	10.3/15.3	3.00	1.2	3.02	3.5	2135/2150T/2157
	10.8/15.8				4.0	2145/2150
	11.8/16.8				5.0	2168T/2171T
	12.5/17.5				5.84	2171/2185X
Standard	9.3/14.3	2.0 (THR)	1.2	3.02	3.5	2135/2150T/2157
	9.8/14.8				4.0	2145/2150
	10.8/15.8				5.0	2168T/2171T
	11.5/16.5				5.84	2171/2185X
Alternate						

A3	2025/03/19	Standardization Drawing	CP	OPERATION	DRAW	DATE	SCALE	Fit	PART NO.
A2	2018/01/22	Modify P/N	Ruipeng	x.X $\pm 0.40$	CP	2025/03/19	UNIT	mm	1115-12XXXXXXRXXXC0XX
A1	2014/05/09	Change Dim A--B, B--A	-----	x.XX $\pm 0.25$	CHECK	DATE	SIZE	A4	TITLE:
A0	2014/01/16	NEW	JYHuang	x.XXX $\pm 0.15$	TANG	2025/03/19	SHEET	1/2	PH2.54 DUAL ROW 90° H=1.5 PLANE BENDING
REV	DATE	MODIFICATION DESCRIPTION	CHANGE	Angle $\pm 3'$	APPROVE	DATE	PROJ.		Customer NO.
				DIM TOL	Steven Zhao	2025/03/19			

**WCON**  
Http: www.wcon.com

WCON-Dongguan  
Tel: +86 769 85358920  
Fax: +86 769 85358915  
E-mail: sales@wcon.com

WCON-Kunshan  
Tel: +86 512 57468408  
Fax: +86 512 57468468  
E-mail: sales@wcon.com

# HSF

Packing:

Packaging Quantity Refers To The Following Table

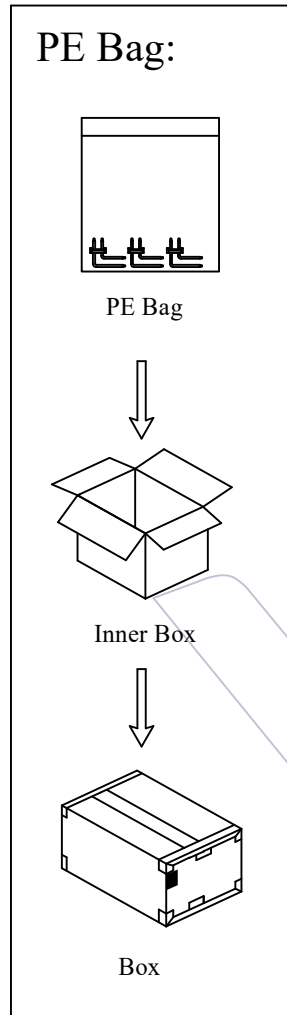

PINS /Row	Q' ty/Bag L≤10.0	PINS /Row	Q' ty/Bag L≤10.0	PINS /Row	Q' ty/Bag 10.0<L≤16.0	PINS /Row	Q' ty/Bag 10.0<L≤16.0
1	1,000	21	100	1	1,000	21	100
2	1,000	22	100	2	1,000	22	100
3	1,000	23	100	3	1,000	23	100
4	1,000	24	100	4	500	24	100
5	500	25	100	5	500	25	100
6	500	26	100	6	500	26	100
7	500	27	100	7	300	27	100
8	500	28	100	8	300	28	100
9	500	29	100	9	200	29	100
10	500	30	100	10	200	30	50
11	300	31	100	11	200	31	50
12	300	32	100	12	200	32	50
13	300	33	100	13	200	33	50
14	300	34	100	14	200	34	50
15	200	35	100	15	200	35	50
16	200	36	100	16	200	36	50
17	200	37	100	17	200	37	50
18	200	38	100	18	200	38	50
19	200	39	100	19	200	39	50
20	100	40	100	20	100	40	50

A3	2025/03/19	Standardization Drawing	CP	OPERATION		DRAW	DATE	SCALE	Fit	PART NO.
A2	2018/01/22	Modify P/N	Ruipeng	x.X	±0.40	CP	2025/03/19	UNIT	mm	1115-12XXXXRXXXCOXX
A1	2014/05/09	Change Dim A--B,B--A	-----	x.XX	±0.25	CHECK	DATE	SIZE	A4	TITLE:
A0	2014/01/16	NEW	JYHuang	x.XXX	±0.15	TANG	2025/03/19	SHEET	2/2	PH2.54 DUAL ROW 90° H=1.5 PLANE BENDING
REV	DATE	MODIFICATION DESCRIPTION	CHANGE	Angle	± 3'	APPROVE	DATE	PROJ.	⊕	Customer NO.
				DIM	TOL	Steven Zhao	2025/03/19			



Http: [www.wcon.com](http://www.wcon.com)

WCON-Dongguan Tel: +86 769 85358920 Fax: +86 769 85358915 E-mail: <a href="mailto:sales@wcon.com">sales@wcon.com</a>	WCON-Kunshan Tel: +86 512 57468408 Fax: +86 512 57468468 E-mail: <a href="mailto:salesks@wcon.com">salesks@wcon.com</a>
---	--